

CH-PL55-U50

[Chain PL55-U] Plastic Standard Link Barrier Chain

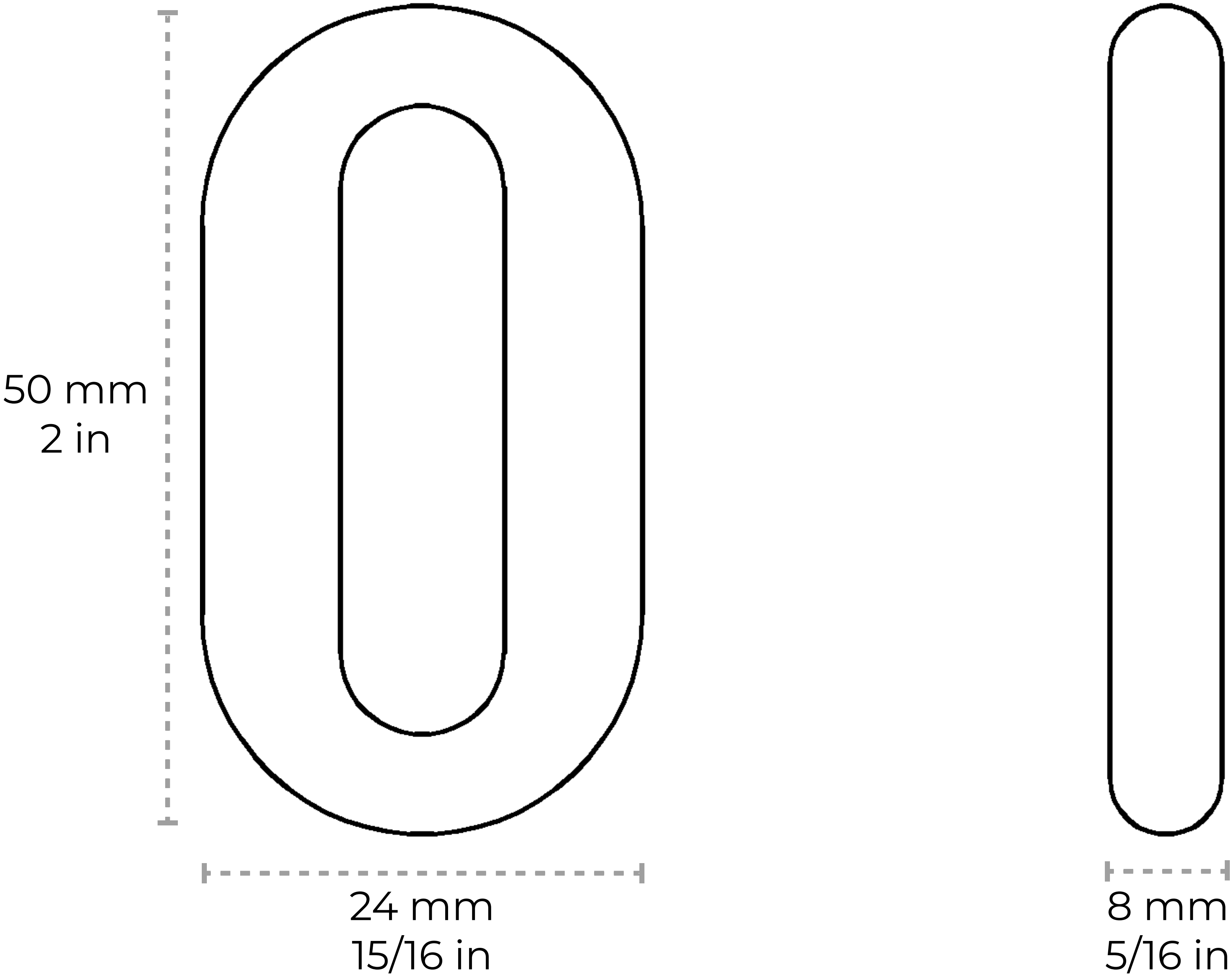

Material	Plastic
Welding Type	Unwelded
Max Load	33 lbs
Weight per Foot	0.03 lbs/ft
Main Link Measurements	Length: 50 mm 2 in Width: 24 mm 15/16 in Diameter: 8 mm 5/16 in

Contact:

1-360-392-8121
<https://www.rchhardware.com>

