

# CH-BR30-U43

[Chain BR30-U] Brass Loop Chandelier Chain

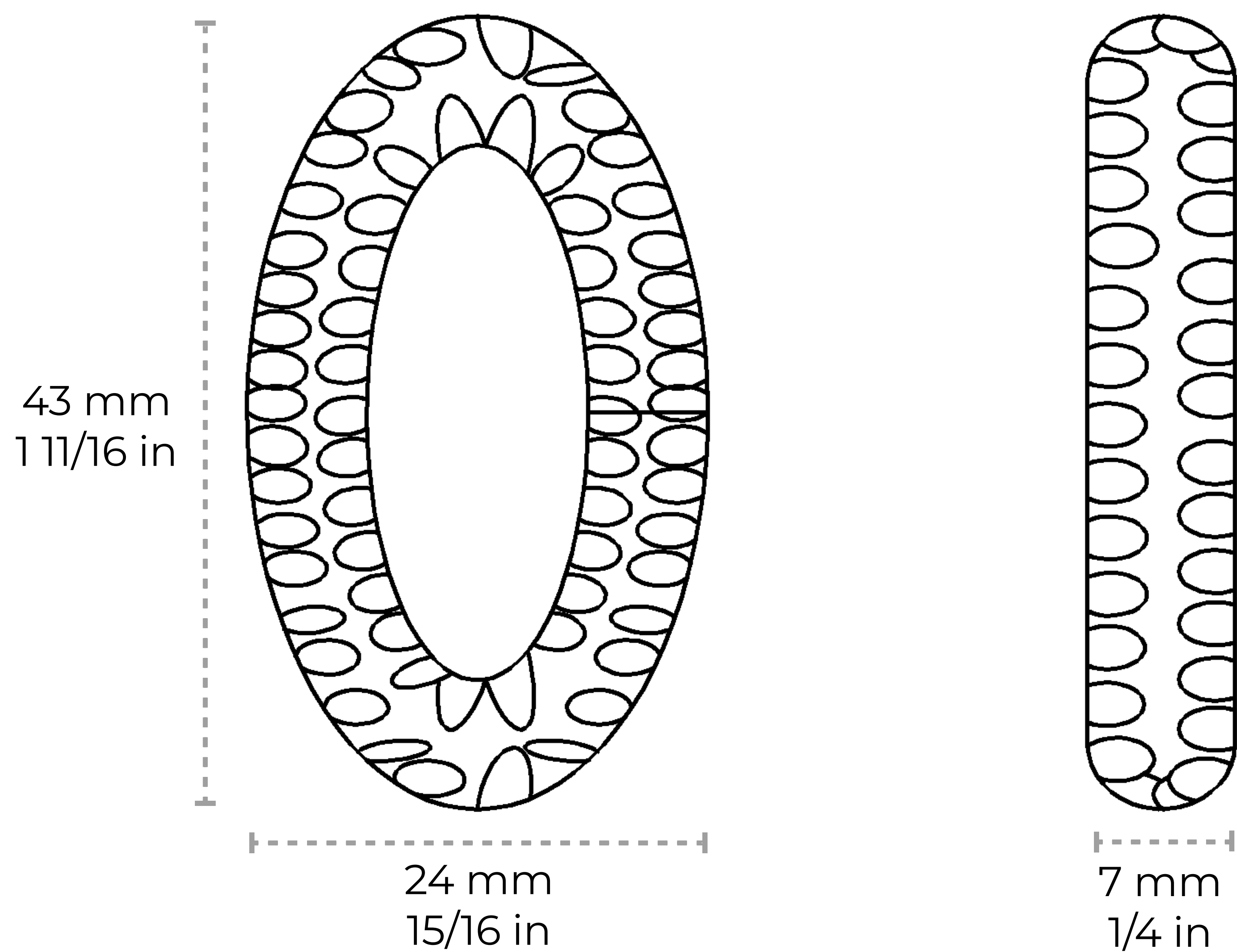

Material	Brass
Welding Type	Unwelded
Max Load	85 lbs
Weight per Foot	0.69 lbs/ft
Main Link Measurements	Length: 43 mm 1 11/16 in Width: 24 mm 15/16 in Diameter: 7 mm 1/4 in

## Contact:

1-360-392-8121

<https://www.rchhardware.com>

