

# CH-BR32-H75

## [Chain BR32-H] Brass Round Chandelier Chain

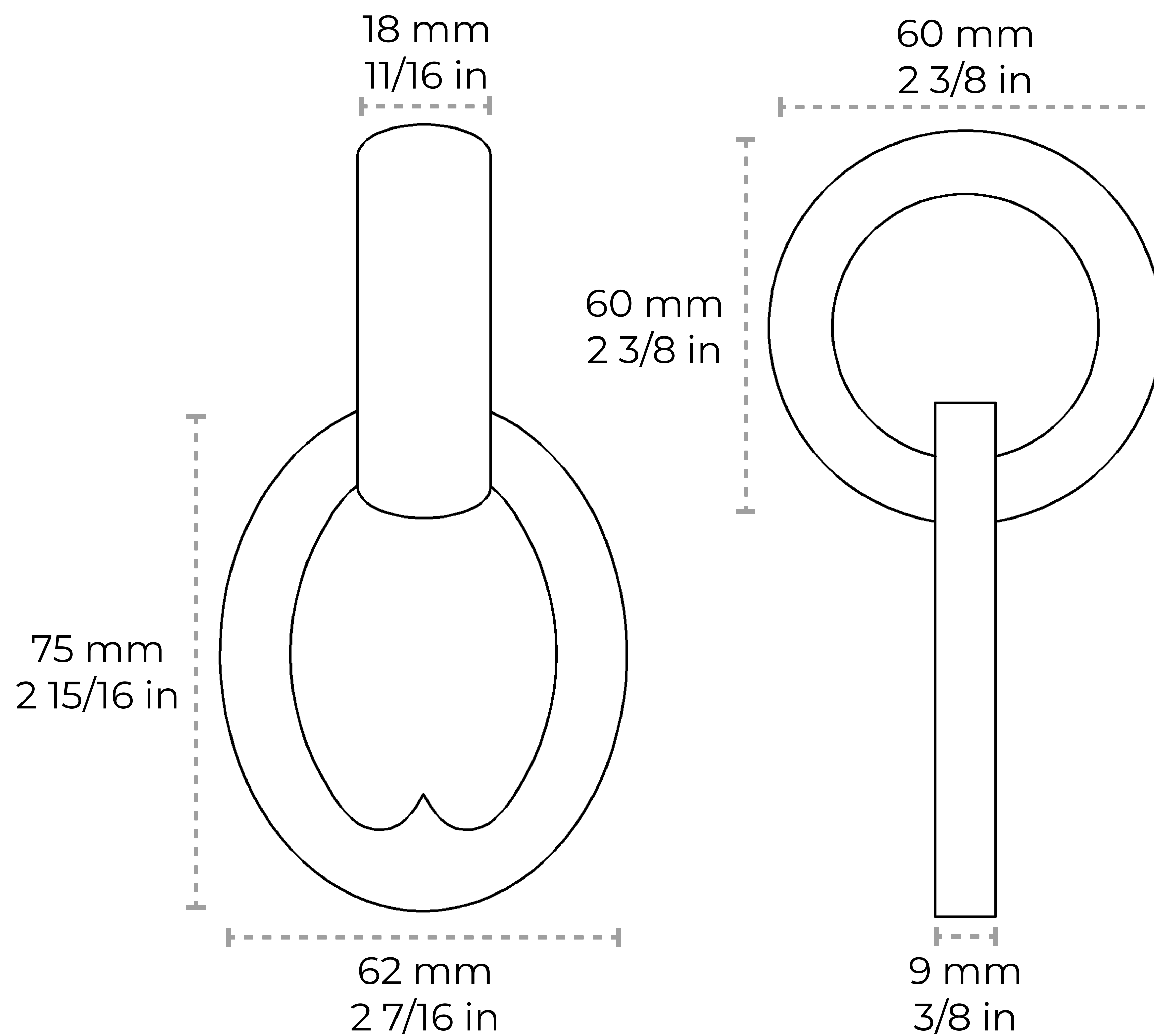

Material	Brass
Welding Type	Hinge
Max Load	150 lbs
Weight per Foot	2.25 lbs/ft
Main Link Measurements	Length: 75 mm 2 15/16 in Width: 62 mm 2 7/16 in Diameter: 9 mm 3/8 in
Connecting Link Measurements	Length: 60 mm 2 3/8 in Width: 60 mm 2 3/8 in Diameter: 18 mm 11/16 in

### Contact:

1-360-392-8121

<https://www.rchhardware.com>

